

OPERATION MANUAL & PART KITS

TM1 pumps ©

TM1 - 15 / 30 / 60 / 120 Series *

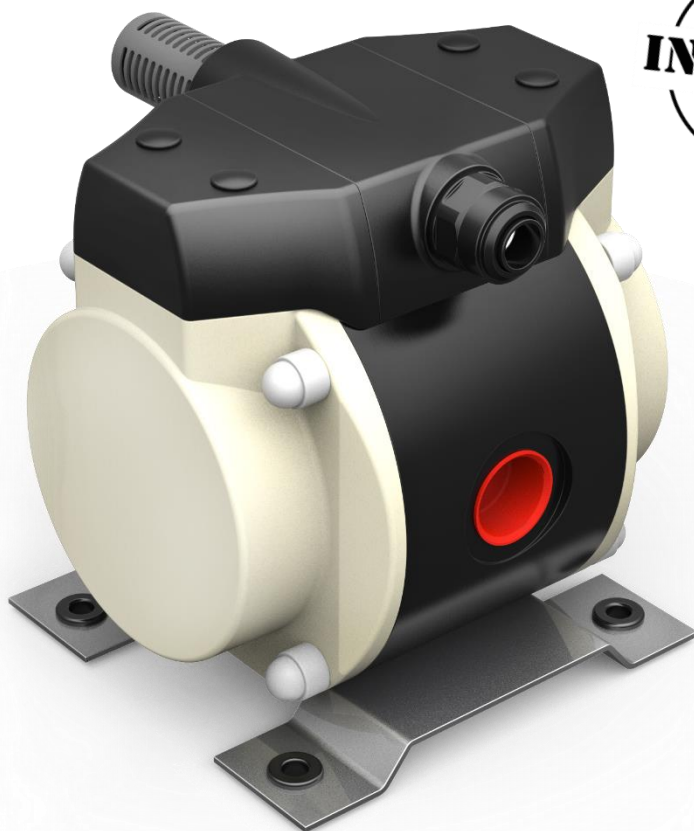

* ex PD

Table of Contents

	Page
• Table of Contents	2
• Important Safety Information	3
• Introduction	4
• ATEX Certificate (only for approved types)	5
• ATEX for use in potential explosive atmospheres	6
• Installation of the pump	7
• Technical pump details	8 /9 /10
• Explanation of materials	11
• Liquid wetted part kits	12
• Main parts list	13
• Torque from bolts & nuts	14
• How to disassemble and assemble the pump	15
• Trouble Shooting	16

IMPORTANT SAFETY INFORMATION



Read before installation and start-up



- The pump must not be used for other purposes than recommended and quoted for without consulting your Tecno-Matic distributor.
- Liquids not suitable for the pump can cause damages to the pump unit and imply risk of serious personal injury. Always consult your Tecno-Matic distributor if you are not sure of the compatibility of fluids with the pump materials including the elastomers.
- **HAZARD WARNING - POSSIBLE EXPLOSION**
HAZARD can result if 1, 1, 1-Trichloro ethane, Methylene Chloride or other Halogenated Hydrocarbon Solvents are used in pressurized fluid systems having Aluminium wetted parts. Death, serious bodily injury and/or property damage could result.
- The pump must always be installed and used in accordance with existing local and national sanitary and safety regulations and laws.
- The pump can create fluid pressures equal to the air supply pressure. Do not exceed the maximum permissible air supply pressure of 7 bar. The total hydraulic pressure (system pressure + differential pressure) must never exceed 7 bar.
- Do not exceed the recommended operating temperatures of the pump. The maximum temperature limitations are based on mechanical stress only and various liquids/chemicals may reduce the maximum safe operating temperatures of the pumps.
- **Diaphragms:** can operate continuously between -25 °C and +85 °C.
- **Pump housing:** can be used between -25 °C and +100 °C. but is depending of used pump body material. (check page "explanation of materials")
- Inside the pump two diaphragms are separating the pumped liquid from the air supply. When a diaphragm ruptures fluid may be expelled through the air exhaust port. If dangerous liquids are handled always connect the air exhaust port with a suitable container in a safe location. When the product source is at a higher level than the pump (flooded suction), the exhaust should be piped to a higher level than the product to prevent spills caused by siphoning.
- Never operate a pump that is leaking, damaged, corroded or otherwise unable to contain the internal fluid or air pressure.
- Never exceed the recommended service and inspection intervals for the diaphragms and air motor parts. (pump inspection at least ones per operating day)
- Never put your face or body near the pump air exhaust while the pump is operating. Always shut off the air supply and disconnect it from the pump before making repairs to the pump.
- Be sure to relief all pressure from the discharge and suction pipes/hoses prior to disconnecting the pump from the system.
- Static electricity can be created when the pump is operating. Always use conductive pumps in hazardous environments or for flammable fluids. Pumps must be properly grounded. Strictly follow the local safety regulations for hazardous environments.
- Never use, under no circumstances, the pumps for pumping non-conductive flammable or explosive fluids.
- The diaphragm pumps do not exceed a noise level rating of 80 dB(A) but still it is advised always to wear ear protection when you are working or standing close to an operating diaphragm pump. Noise can be substantially reduced by leading the exhaust air away through a hose connected to the air exhaust port.
- Always wear suitable safety clothing, glasses, handgloves when handling the pump.
- Install shut-off valves on both side of the pump to be able to shut off the in- and outlet before service and maintenance. Check to see that the pump can be drained without injuring anyone and without damaging the environment or nearby equipment.
- Always install a separate shut-off valve for the air supply easily accessible for manoeuvring.
- Pressure variations may cause vibrations in the piping systems. Connect the pump to the pipes via flexible coupling/hoses. Ensure that the pipes/fittings are securely bolted to the foundation.
- Improper installation can cause fatal injuries.
- If the pump handles liquids hazardous for person or environment, some sort of collector must be installed into which leakage can be led.
- If the surface temperature of the system or parts of the system exceeds 60°C, these areas must be marked with warning text reading "Hot surface" to avoid burns.
- Never use other compressed gases than air to operate the pump.
- Before starting the pump always make sure that the discharge point of the piping system is clear and safe and that all persons have been warned to stand clear.
- Always check the flow direction prior to start-up.
- Never operates pump dry with use of abrasive liquids.
- Do NOT remove on the air-inlet mounted quick air-coupler. The air-coupler is covered by this sticker:

12 mm PUSH-IN AIR COUPLER
DO NOT REMOVE !!!
WARRANTY WILL EXPIRE !!

Introduction

GENERAL

The air operated diaphragm pump series are manufactured by Tecno-Matic Europe s.r.o. in Europe and is marketed and sold by a net of authorised distributors.

This instruction manual contains important information and must be read carefully before installation, service and maintenance. The manual must be kept easily accessible to the operator.

RECEPTION

Remove all packing materials immediately after reception. Check the consignment for damage at once and make sure that the name plate / type designation is in accordance with the packing slip and your order.

In case of damage and / or missing parts a report should be drawn up and presented to the carrier instantly. Notify your Tecno-Matic distributor.

All pumps have the type specification (Type) printed on the name plate which is located on the pump housing. This specification should always be quoted in all correspondence with your distributor.

EXPLANATION OF PUMP MODEL

TM1	30	0.5"	P	T	PK	ZX
↓	↓	↓	↓	↓	↓	↓
1	2	3	4	5	6	7

- 1 = Tecno-Matic pump, series 1
- 2 = Max. capacity (l/min)
- 3 = Connection size
- 4 = Material pump body
- 5 = Diaphragm
- 6 = Valve
- 7 = Extra options

STORAGE

If the pump is not installed immediately it is recommended to store it in a dry, clean and cool location. Each Tecno-Matic pump is tested by an qualified engineer** with compressed air with water as liquid according to the enclosed test report. Note: Rest water from the test may stay behind in the pump.

** Test report is personally signed by the qualified engineer.

Declaration of conformity

according to EU directive 2014/34/EU

Manufacturer

Tecno-Matic Europe s.r.o.

Malhotice 128

753 53 Všechnovice

Czech Republic

Declares hereby that

The following product families, if ordered as Atex pump or Atex pump unit, are meeting the requirements set forth in EU directive 2014/34/EU of April 2014.

If the product is modified without written permission, or if the safety instructions in the instruction manual are not being followed, this declaration becomes invalid.

• Product families: Tecno-Matic PD, AOPD and AODD series

• Notified body: FYZIKÁLNĚ TECHNICKÝ ZKUŠEBNÍ ÚSTAV
Pikartská 1337/7
7 Ostrava – Radvanice
Czech-Republic

• Tech. File Ref: A426-15

• Standards: Applicable harmonised standards
EN 13463-1
EN 13463-5
EN 1127-1

• Marking: The marking includes the symbol and the technical file reference.

Special conditions for safe use are specified the Ex-Instruction Manual.

Malhotice, Czech Republic, 2017-01-01



Tecno-Matic Europe s.r.o.
Malhotice 128, 753 53 Všechnovice
IČO: 27766187, DIČ: CZ27766187
T: +420 581 612 053, www.tecnomaticpump.com

Petr Vojtěšek | General Manager of Tecno-Matic Europe s.r.o.

Use in potential explosive atmospheres

Tecno-Matic diaphragm pumps for use in potential explosive atmospheres

In accordance with European guidelines, equipment to be used in potential explosive atmospheres, must be safe for use in these environments.

CERTIFIED SAFETY!

Tecno-Matic pumps meets these requirements, and are certified for use in these areas.*
The pumps may be used in Zone 1 and 2, for gases, and Zone 21 and 22 for dust.

Equipment groups (Annex I of the EU directive 2014/34/EU)							
Group I (mines, mine gas and dust)		Group II (other explosive atmospheres gas/dust)					
Category M		Category 1		Category 2		Category 3	
1	2	G (gas) (Zone 0)	D (dust) (Zone 20)	G (gas) (Zone 1)	D (dust) (Zone 21)	G (gas) (Zone 2)	D (dust) (Zone 22)
For equipment providing a very high level of protection when endangered by an explosive atmosphere	For equipment providing a high level of protection when likely to be endangered by an explosive atmosphere	For equipment providing a very high level of protection when used in areas where an explosive atmosphere is very likely to occur		For equipment providing a high level of protection when used in areas where an explosive atmosphere is likely to occur		For equipment providing a normal level of protection when used in areas where an explosive atmosphere is less likely to occur	

The Tecno-Matic diaphragm pumps comply with category 2 equipment, providing a high level of protection when used in areas where an explosive atmosphere is likely to occur.

Correct grounding ATEX Pumps

ATEX compliant pumps are suitable for use in explosive atmospheres when the equipment is properly grounded in accordance with local electrical codes. Pumps equipped with electrically conductive diaphragms are suitable for the transfer of conductive or non-conductive fluids of any explosion group.

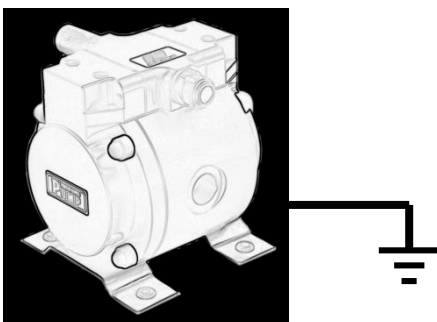

When operating pumps equipped with non-conductive diaphragms that exceed the maximum permissible projected area, as defined in EN 13461-1: 2009 section 6.7.5 table 9, the following protection methods must be applied:

- Equipment is always used to transfer electrically conductive fluids or
- Explosive environment is prevented from entering the internal portions of the pump, i.e. dry running

For further guidance on ATEX applications, please consult our distributor.

Installation of the pump

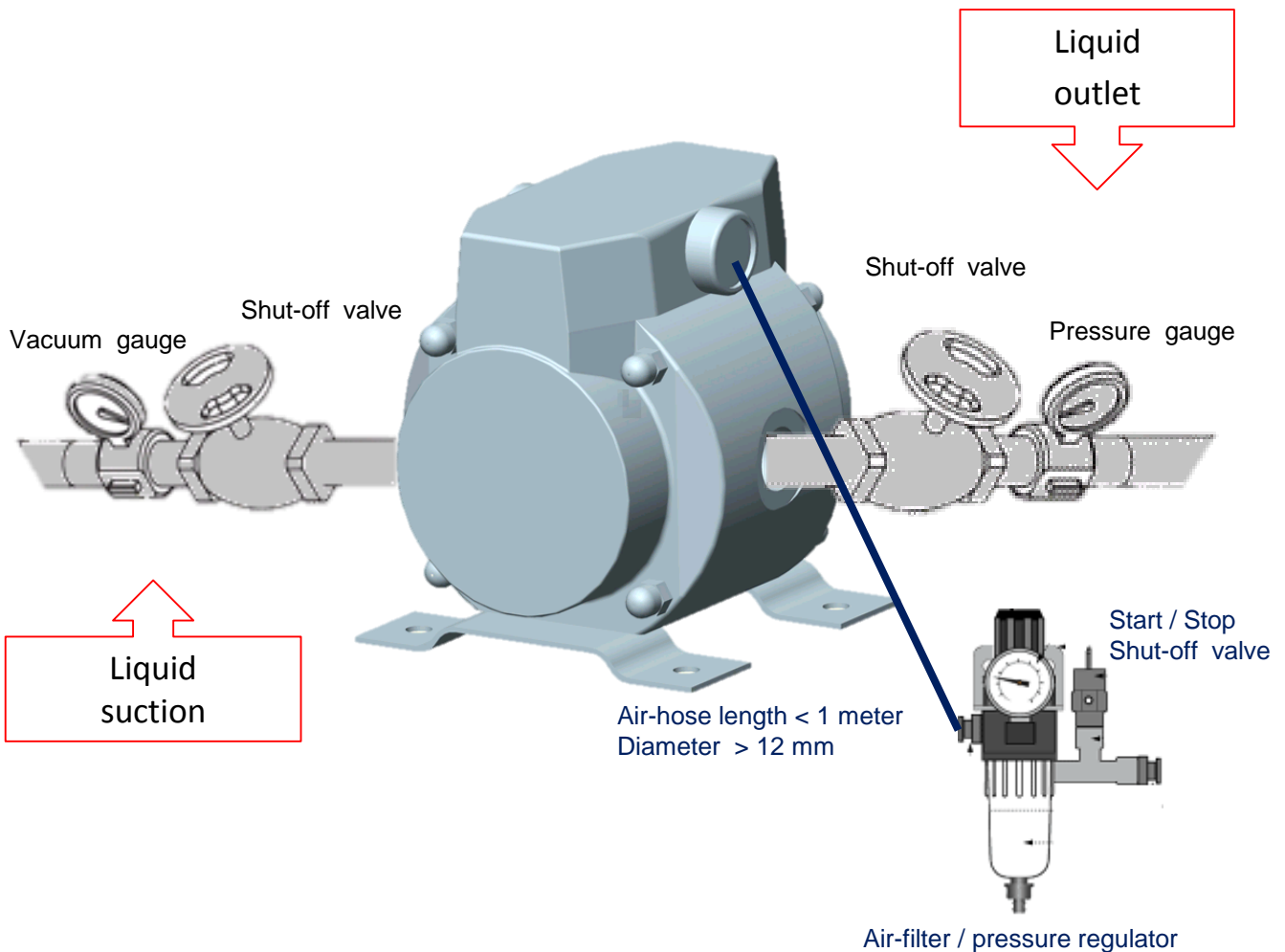

Note !!:

- Liquid suction- and pressure tube diameter must have at least the same diameter as pump connections.
- Start / Stop function pump by open or close air-valve.

Technical Pump Details TM1-30

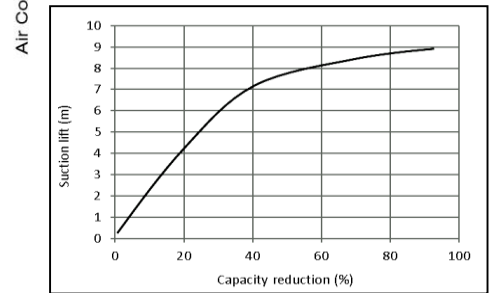
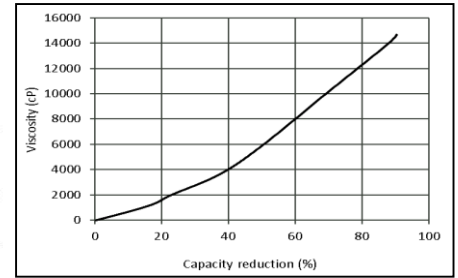
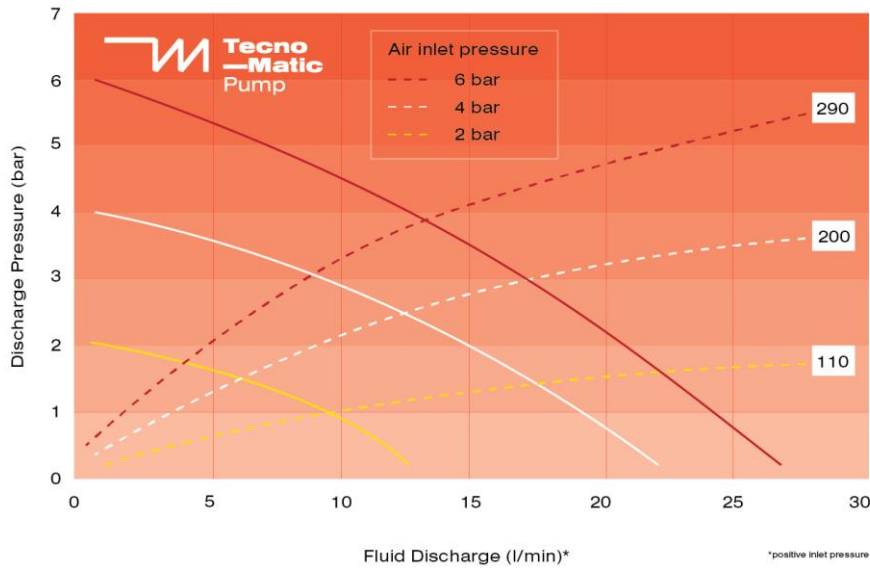

Available types

Type

TM1-30/0.5"-A-T-PK
TM1-30/0.5"-HDPE-T-PK
TM1-30/0.5"-HDPE-T-PK-ZK
TM1-30/0.5"-P-T-PK
TM1-30/0.5"-P-T-PK-ZK
TM1-30/0.5"-S-T-PK
TM1-30/0.5"-S-T-PK-ZK

Max. weight: 3 Kg

A	65 mm	K	12 mm
B	65 mm	L	145 mm
C	100 mm	R	15 mm
D	100 mm	S	120 mm
E	15 mm	W	140 mm
H	145 mm	in-outlet	1/2"

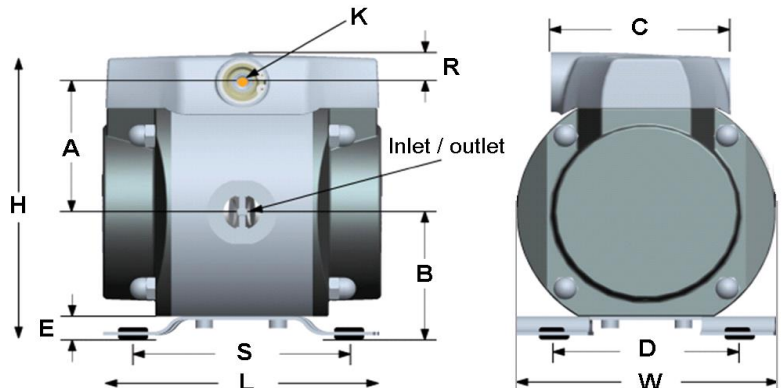

Technical Pump Details TM1-60

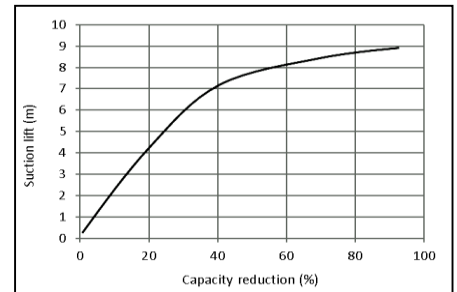
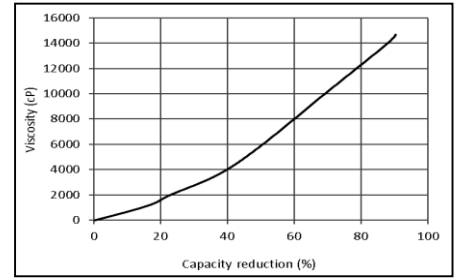
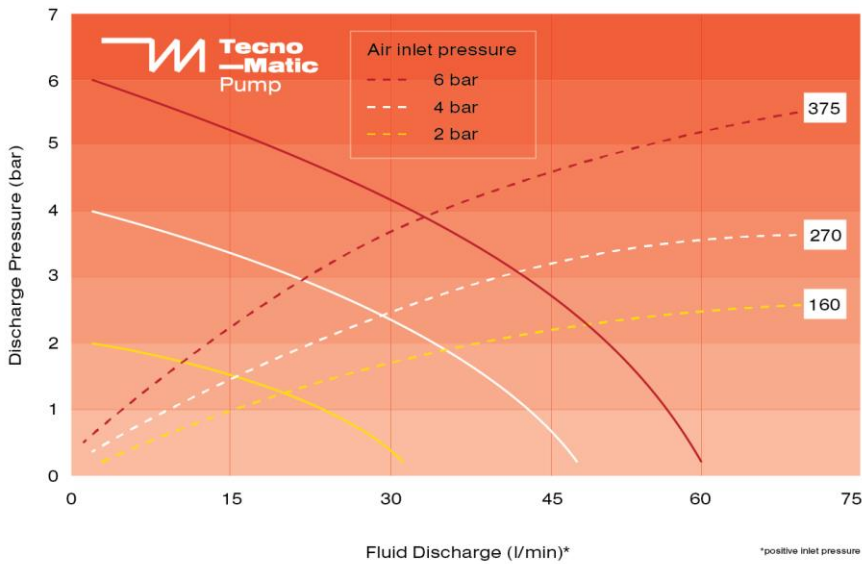

Available types

Type

TM1-60/0.75"-A-T-PK
TM1-60/0.75"-HDPE-T-PK
TM1-60/0.75"-HDPE-T-PK-ZK
TM1-60/0.75"-P-T-PK
TM1-60/0.75"-P-T-PK-ZK
TM1-60/0.75"-S-T-PK
TM1-60/0.75"-S-T-PK-ZK

Max. weight: 5 Kg

A	75 mm	K	12 mm
B	75 mm	L	145 mm
C	100 mm	R	15 mm
D	100 mm	S	120 mm
E	15 mm	W	140 mm
H	165 mm	in-outlet	3/4"

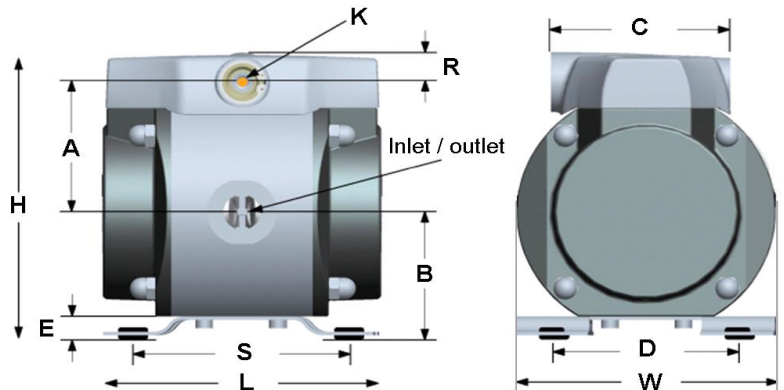

Technical Pump Details TM1-120

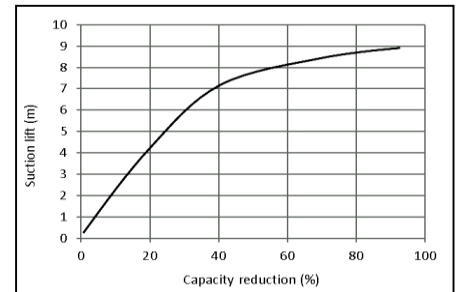
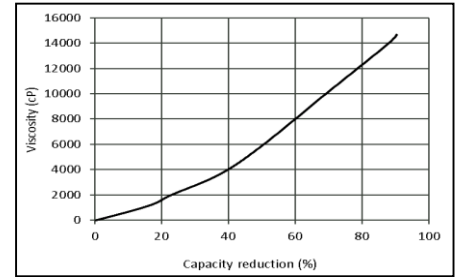
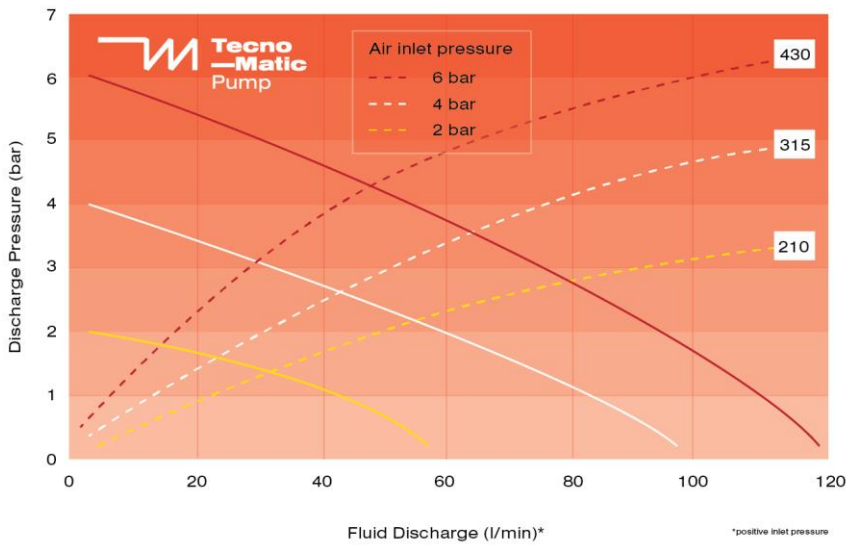

Available types

Type

TM1-120/1.25"-A-T-PK
TM1-120/1.25"-HDPE-T-PK
TM1-120/1.25"-HDPE-T-PK-ZK
TM1-120/1.25"-P-T-PK
TM1-120/1.25"-P-T-PK-ZK
TM1-120/1.25"-S-T-PK
TM1-120/1.25"-S-T-PK-ZK

Max. weight: 7 Kg

A	100 mm	K	12 mm
B	100 mm	L	180 mm
C	100 mm	R	15 mm
D	135 mm	S	150 mm
E	15 mm	W	185 mm
H	210 mm	in-outlet	1-1/4"

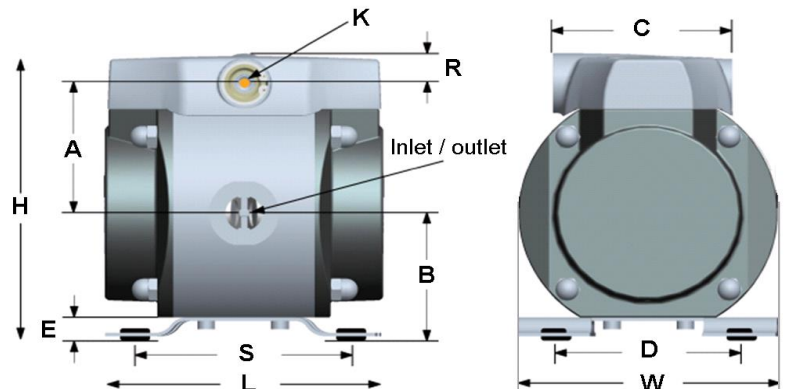

Explanation of materials

A	Aluminium <i>min. temp.</i> - 25 °C <i>max. temp.</i> + 150 °C	High grade casted aluminum AISi12Mn according to CSN 424331
P	Polypropylene <i>min. temp.</i> - 0°C <i>max. temp.</i> + 95°C	Similar to PE but can tolerate a higher temperature (aca, 100 ° C), PP is highly resistant to chemicals. At higher temperatures (above 60 ° C), the oxidation is accelerated in particular when dealing with metals such as copper and manganese. PP is widely used in chemical industries. Tecno-Matic is adding 30% glass fiber to the mixture, this ensures flexibility and maintains dimension stability.
S	Stainless Steel <i>min. temp.</i> - 25°C <i>max. temp.</i> + 150°C	High grade casted stainless steel AISi 316
PK	Polyether ether ketone <i>min. temp.</i> - 25 °C <i>max. temp.</i> + 160°C	This high performance engineering plastic is extremely resistant to all kinds of adverse or critical operating conditions. The material is resistant to high constant chemical resistance. It is applied in the chemical industry as high-quality, mechanically stressed parts.
T	Polytetrafluoroethylene <i>min. temp.</i> - 25°C <i>max. temp.</i> + 150°C	Very well chemical properties. Low friction coefficient. PTFE can not be glued. Its hydrophobic: neither water nor water-containing substances wet PTFE. It is used for reactive and corrosive chemicals. Gaskets, bearings, pump parts, etc. produced from PTFE.
ST	Santoprene <i>min. temp.</i> - 25°C <i>max. temp.</i> + 125°C	Is part of the thermoplastic elastomer (TPE) family of polymers, combining the characteristics of vulcanized rubber with the processing properties of thermoplastics. Purchased directly from Exxon Mobil – inventor of this material.
NBR	Nitrile rubber <i>min. temp.</i> - 25 °C <i>max. temp.</i> + 100°C	Also known as Buna-N. This form of synthetic rubber is generally resistant to oil, fuel, and other chemicals. The more nitrile within the polymer, the higher the resistance to oils but the lower the flexibility of the material. By our special diaphragm shape the most ideal mix can be produced. Nitrile rubber is in generally resistant to aliphatic hydrocarbons.

Liquid Wetted Part kits

K102-100

Check valve kit with retainers TM1-30

K102-100-PEEK

Metal free version TM1-30

K102-101

Check valve kit with retainers TM1-60

K102-101-PEEK

Metal free version TM1-60

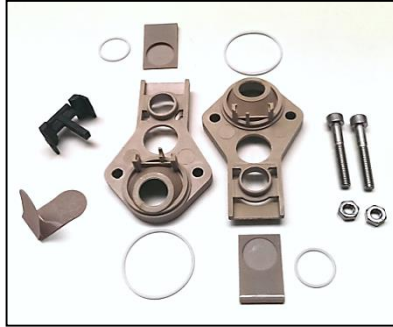

K102-102

Check valve kit with retainers TM1-120

K102-102-PEEK

Metal free version TM1-120



KF107-002

Fixed SST shaft kit:

TM1-30, 60 Series

KF107-003

Fixed SST shaft kit:

TM1-120 Series

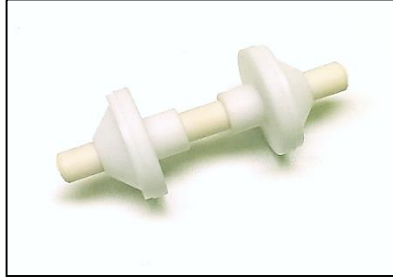

KF107-002-Ceramic

Fixed ceramic shaft kit:

TM1-30, 60 Series

KF107-003-Ceramic

Fixed ceramic shaft kit:

TM1-120 Series

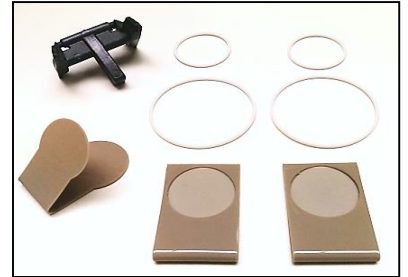

K102-001 Check valve kit TM1-30

K102-002 Check valve kit TM1-60

K102-003 Check valve kit TM1-120



KF105-001

DIAPHRAGM KIT PTFE for TM1-30 Series

KF105-002

DIAPHRAGM KIT PTFE for TM1-60 Series

KF105-003

DIAPHRAGM KIT PTFE for TM1-120 Series



KF105-001-PEEK

DIAPHRAGM KIT PTFE / PEEK for TM1-30 Series

KF105-002-PEEK

DIAPHRAGM KIT PTFE / PEEK for TM1-60 Series

KF105-003-PEEK

DIAPHRAGM KIT PTFE / PEEK for TM1-120 Series

Further parts list



KF103-003
High Speed POM-C/ALU Air Motor kit for
TM1-30 / 60 Series

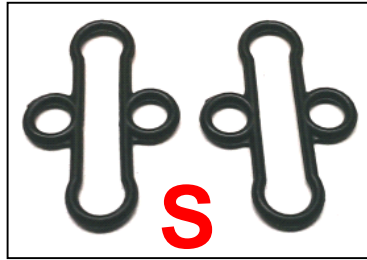

K101-020
Air Motor Gaskets for
TM1-30, 60, 120 Series



KF103-004
High Speed POM-C/Alu Air Motor kit for
TM1-120 Series

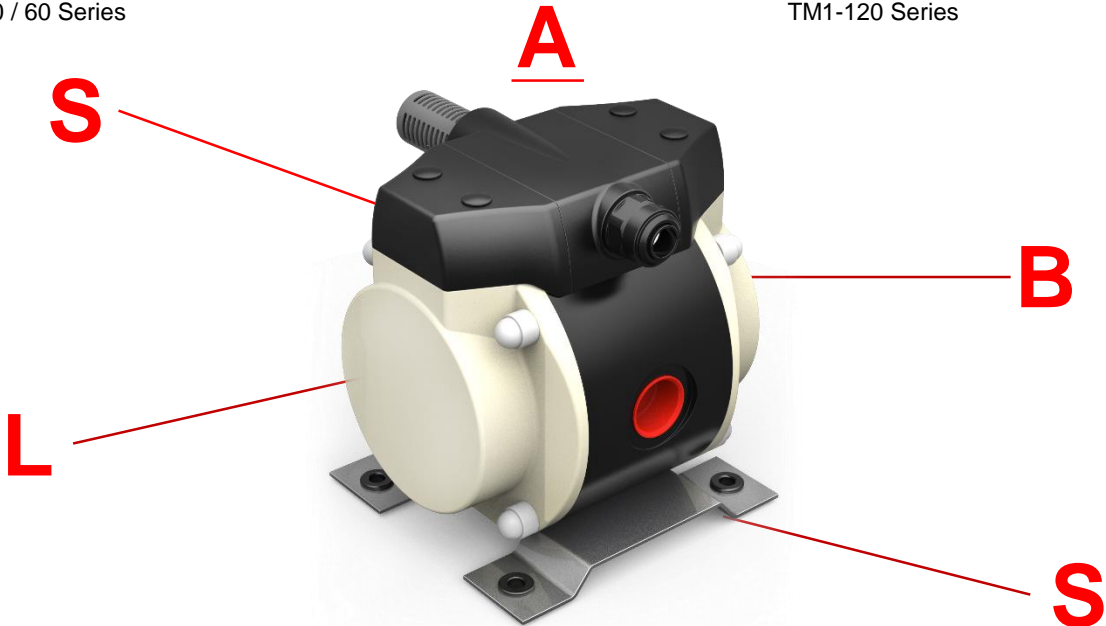

L = Lids:	TM1-30 Series	Part No.:	TM1-60 Series	Part No.:	TM1-120 Series	Part No.:
			KF104-001	Part No.:	KF104-002	Part No.:

B = Pump Body	TM1-30 Series	Part No.:	TM1-60 Series	Part No.:	TM1-120 Series	Part No.:
	HDPE	KF109-201-HDPE	HDPE	KF109-202-HDPE	HDPE	KF109-203-HDPE
	P	KF109-201-P	P	KF109-202-P	P	KF109-203-P
	PTFE	KF109-201	PTFE	KF109-202-PTFE	PTFE	KF109-203-PTFE

S = Footplate	TM1-30 Series	Part No.:	TM1-60 Series	Part No.:	TM1-120 Series	Part No.:
			1003-001	Part No.:	1003-001	Part No.:

Torque from bolts and nuts

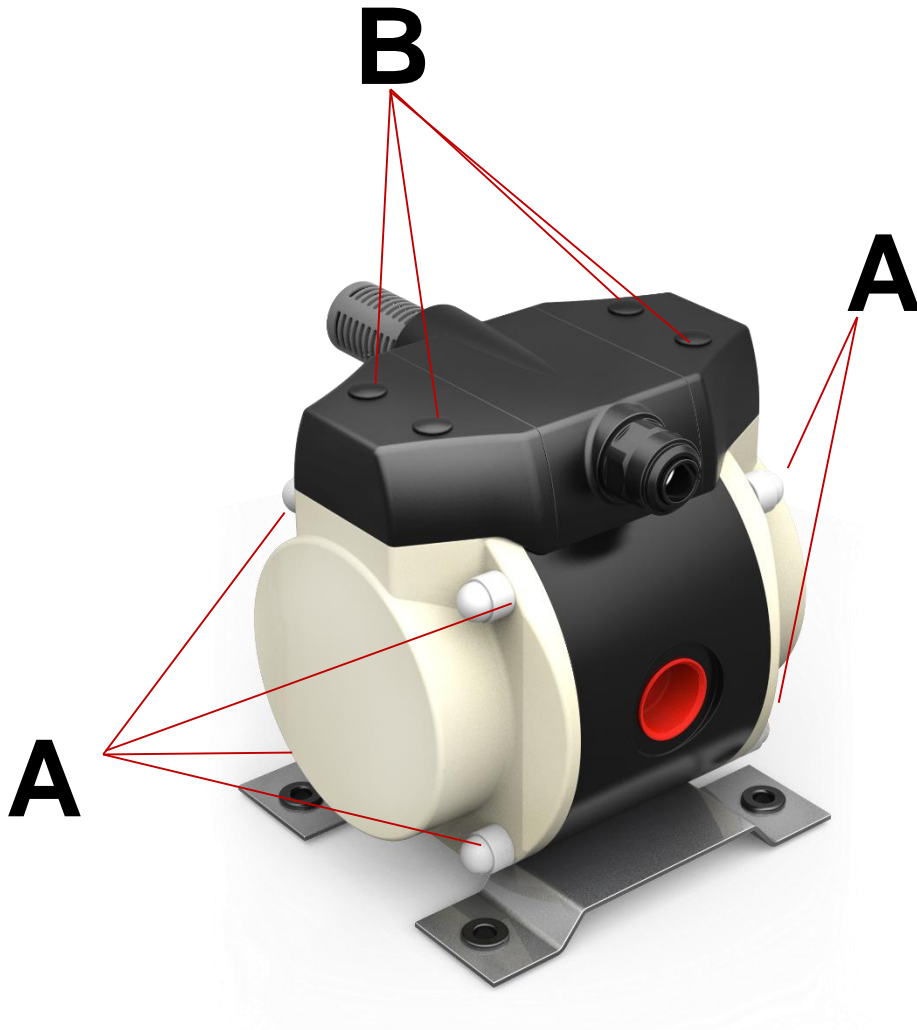

TM1-30/60/120 Series

A. Lid nuts

10 Nm

B. Air-motor bolts

6 Nm

Most simply to explain by video



Scan the QR code with your smartphone

or

Go to website www.tecnomaticpump.com

or

Contact your distributor !

Trouble shooting

Pump will not operate	<ul style="list-style-type: none"> • Check there is sufficient air pressure / volume • Check that the emergency stop valve is open. • Check inlet air filter and muffler for dirt. • Check that the suction- and discharge lines are open. • Open the pump and check the diaphragms. • Check that the shaft moves freely. • Check valves are moving • Check for dirt in the pump chambers
Pump does not prime	<ul style="list-style-type: none"> • Check that the suction and discharge lines are open. • Check that all suction connections are air tight. • Check if suction tube is not too long before liquid can enter pump. • Increase the stroking speed by increasing air-pressure • Check if all bolts & nuts are tightened. • Open pump and check the diaphragms and valves • Check if viscosity of liquid is not too high
Erratic pump action/heavy pulsation	<ul style="list-style-type: none"> • Check the diaphragms and valves • Check if the air-pressure is not too high (max. 7 bar) • Check suction side showing no leakage. • Check inlet air filter and muffler for dirt. • Check if outlet liquid flow influenced by adjustable valves.
Pump runs but flow is reduced	<ul style="list-style-type: none"> • Check that the suction and discharge lines are open. • Check that all suction connections are air tight. • Check for possible cavitation. (lower pump speed to match the viscosity of the liquid). • Open the pump and check the valves. • Check inlet air filter and muffler for dirt. • Check liquid viscosity changed by lower temperature • Check dirt has constipated in- outlet of pump.
Fluid comes out of the air exhaust	<ul style="list-style-type: none"> • Check for diaphragm rupture. • Check if all bolts & nuts are tightened.
Air bubbles in the fluid	<ul style="list-style-type: none"> • Check that all suction connections are air tight. • Check for diaphragm rupture. • Check if all bolts & nuts are tightened.

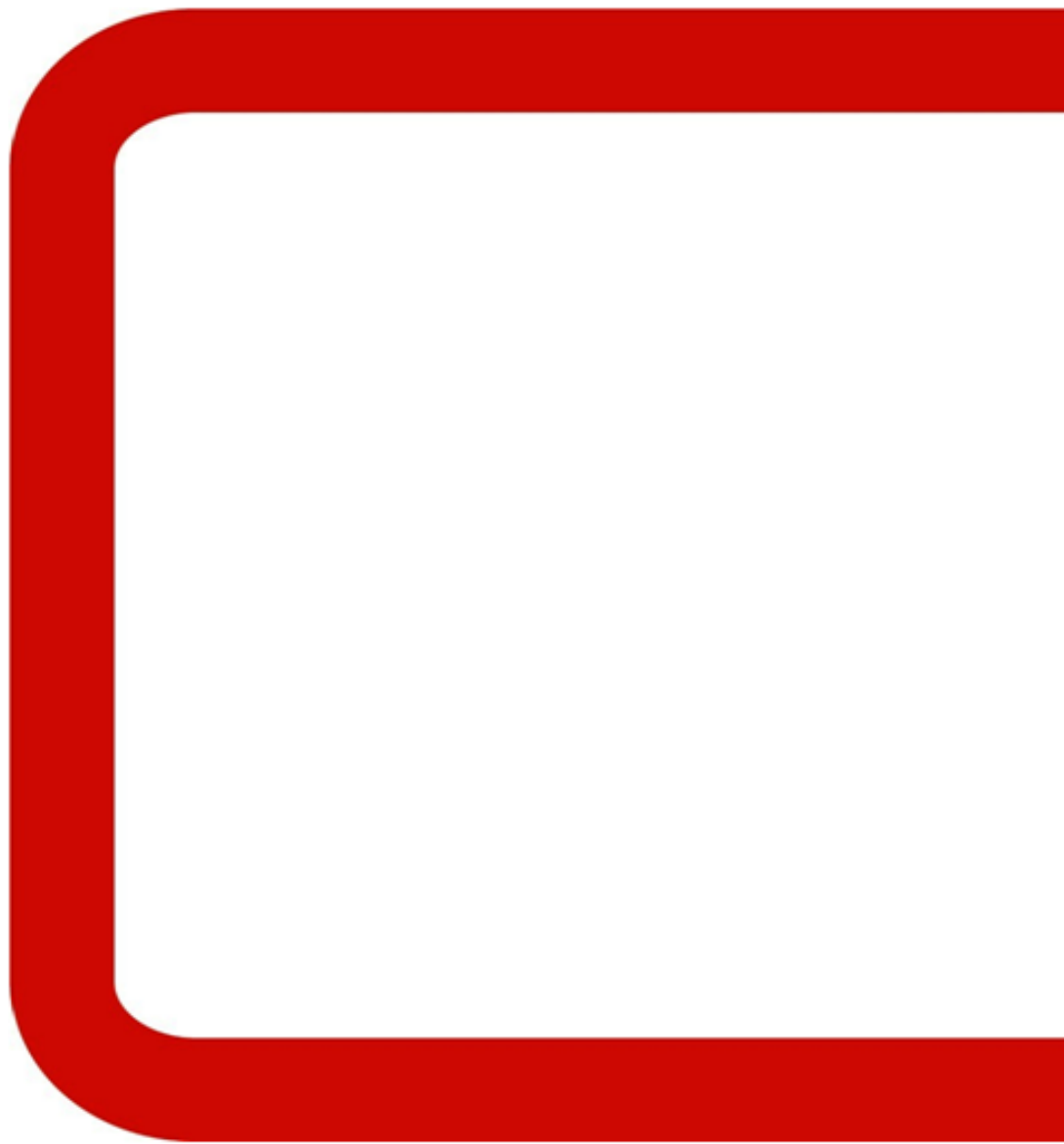

Tecno-Matic Europe s. r. o.
Malhotice 128
753 53 Vsechovice
Czech Republic
Tel. +420 581 612 053

For more information about our worldwide locations, approvals, certifications, and local representatives, please visit www.tecnomaticpump.com.
Tecno-Matic Europe s.r.o. reserves the right to incorporate our latest design and material changes without notice or obligation. Design features, materials of construction and dimensional data, as described in this bulletin, are provided for your information only and should not be relied upon unless confirmed in writing.
Certified drawings are available upon request.
© 2017 Tecno-Matic Europe s.r.o.